



Dept. of Mech. Eng.
CUET

Published Online March 2015 (<http://www.cuet.ac.bd/merj/index.html>)

Mechanical Engineering Research Journal

Vol. 9, pp. 13–17, 2013

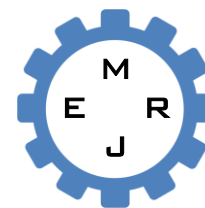

ISSN: 1990-5491

EFFECT OF COWLING ON A CYCLONIC VERTICAL AXIS WIND TURBINE

I. Mustary*, B. Loganathan, H. Chowdhury and F. Alam

School of Aerospace, Mechanical and Manufacturing Engineering, RMIT University, Melbourne, 3001, Australia

Abstract: The primary objective of this paper is to investigate the effect of a cowling device on a cyclonic domestic scale vertical axis wind turbine with semicircular shaped blades under a range of wind speeds. A 16-bladed rotor was initially designed and its torques and angular speeds were measured over a range of wind speeds using a wind tunnel. A cowling device was then developed to enhance the turbine efficiency by directing the air flow from the rear blades into the atmosphere. Maximum power curves as a function of wind speeds were established for each configuration. The results show that the cowling device has positive effect to increase the rotor speed to a significant amount. With the use of the cowling device, the average rotor speed increases by about 26% for the 16-bladed rotor compared to the baseline configuration. The results also indicate that the cowling device can be used to increase the power output of this cyclonic type vertical axis wind turbine especially with a reduce number of blades.

Keywords: Vertical axis wind turbine, wind tunnel, power, torque, rotor

NOMENCLATURE

Symbol	Meaning	Unit
N	rotor speed	(rpm)
ω	yaw angle	(degree)
P	power	(Watt)
T	torque	(Nm)

1. INTRODUCTION

The increasing awareness of global warming and climate change, diminishing fossil fuel energy sources, and tightening carbon emission target require the development of renewable energy resources to generate power [1–4]. Over decades, many research works have been carried out to investigate and enhance the power generation performance of various wind turbine configurations. Most of these research studies have focused on the large scale horizontal axis wind turbines (HAWTs) and vertical axis wind turbines (VAWTs) installations in open areas with a constant undisturbed wind source. However, limited research has been carried out on wind power generation in built-up areas [5,6]. In urban and built-up areas, the atmospheric

wind becomes highly turbulent and exhibits significant fluctuations of gust speed and high variability of wind direction caused by the urban structures and buildings. Under such conditions, existing HAWTs cannot generate power effectively. On the other hand, despite having some advantages (i.e., fewer moving parts, lower tip speed ratio, quieter, lower cost and insensitive to wind direction) over the HAWTs, most VAWTs currently used in urban applications do not produce appreciable power.

One of the major limitations of these current VAWTs is the negative torque generated by the turbines themselves. As a result, this negative torque restricts the turbine rotor from accelerating to higher torque producing speeds. Generally, the negative torque is produced in two different zones: on the returning blade (convex side) and on the rear blades when the swept airflow moves through the rotor and tries to exit at the rear. This exiting airflow impedes the returning blade. In addition, the exiting air stream is directed back into the path of the approaching wind, creating a turbulent zone which not only introduces losses and minimizes efficiency, but also creates pressure fluctuations that cause vibrations in the rotor and the surrounding mountings.

Over the years, researchers have tried to improve the performance of VAWT. Ogawa et al. [7] examined the effect of

* Corresponding author: Email: israt.mustary@gmail.com; Tel: 61 3 99256103; Fax: 61 3 99256108

flow deflector plate and found that the rotor power increases nearly 30 percent. Irabu and Roy [8] studied the effect of a guide box surrounding the turbine and found an increase of efficiency by about 1.5 times with three blades and 1.23 times with two blades compared to the efficiency of the turbine without any guide-box. Altan et al. [9] found that the maximum power coefficient of the Savonius wind rotor was increased by about 38.5% with the optimum curtain arrangement. Therefore, these studies suggested that the efficiency of a Savonius rotor can be increased by using enhancements.

In fact, this study builds on top of a previous work carried out by Alam et al. [10] using RMIT Industrial wind tunnel. As an alternative to existing VAWT systems (e.g., Savonius, Nautilus or Darrieus), a novel concept of Cyclonic Vertical Axis Wind Turbine (CVAWT) which diverts the incoming wind upward and makes use of the stack effect to extract more wind power as it exits through a cowling system. Preliminary testing using a card board model of a CVAWT was carried out by Alam et al [10]. The CVAWT was tested with two configurations over a range of wind speeds (5 to 30 km/h). The first configuration was the bare rotor without a cowling and the other configuration was the bare rotor shrouded with a cowling. Only the speeds of the rotor with these two configurations were tested and their study indicated an increase of rotor speed over 130% with the cowling. However, the study neither considered the effect of the number of blades nor measured the rotor torque and angular velocity which are important parameters to determine the possible power generation by a wind turbine. Therefore, the main purpose of this study is to measure the power output of a model CVAWT for four different configurations using better construction material (e.g., fiber glass) and considering the effect of number of blades.

2. MATERIALS AND METHODS

The Savonius blades were modeled on a variation of classic Savonius rotor. The VAWT used for this study is a semicircle shaped blade made from fiber glass material. Detailed dimensions of the blade are shown in Fig. 1. The blades are mounted in between two circular discs providing equal space. The rotor radius is 150 mm. Two rotors: one with 16 blades and another with 8 blades were constructed. The schematic of the rotors are shown in Fig. 2 and 3. Fig. 4(a) shows the 3D model of the assembly for the 16-bladed turbine rotor and a 3D model of the cowling device is shown in Fig. 4(b). Fig. 5 represents the rotor fitted with the cowling.

To determine the effect of enhancement device on the overall performance of the wind turbine, a cowling was designed in such a way that it can enclose the turbine rotor with a small clearance and can guide the incoming wind through a defined inlet and push the rotor and finally channel out the wind through the confined outlet to the environment. The main function of the cowling is to eliminate the negative torques which prevents the rotor from accelerating to higher torque producing speeds. The cowling was constructed with two hollow PVC cylinders. The outer cylindrical shell is 360 mm in diameter and half of its frontal area is kept closed to prevent the incoming wind hitting

the convex side of the returning blade. The inner shell with 160 mm diameter has an opening to allow the swept wind to exit the turbine through the top instead of at the rear to eliminate the second negative torque.

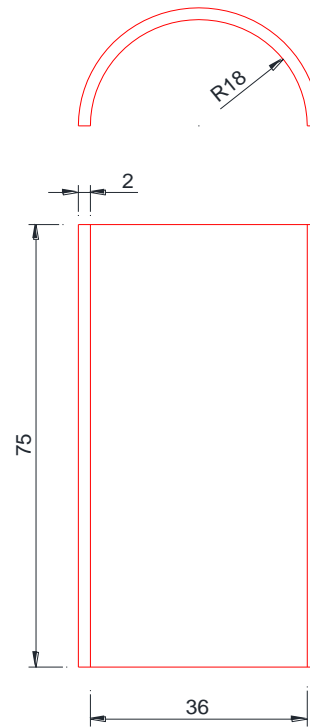

Fig. 1: Dimensions (mm) of the semicircle shaped wind turbine blade.

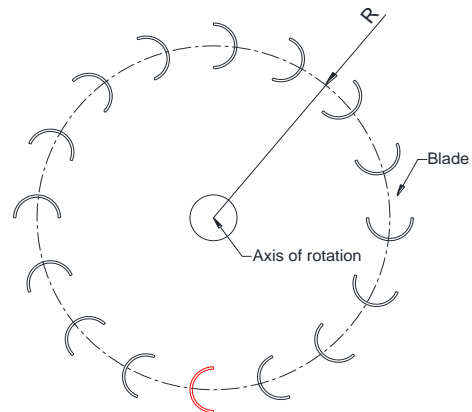

Fig. 2: Top view of 16-bladed wind turbine rotor.

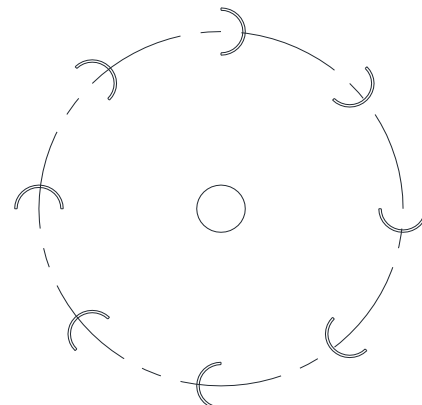

Fig. 3: Top view of 8-bladed wind turbine rotor.

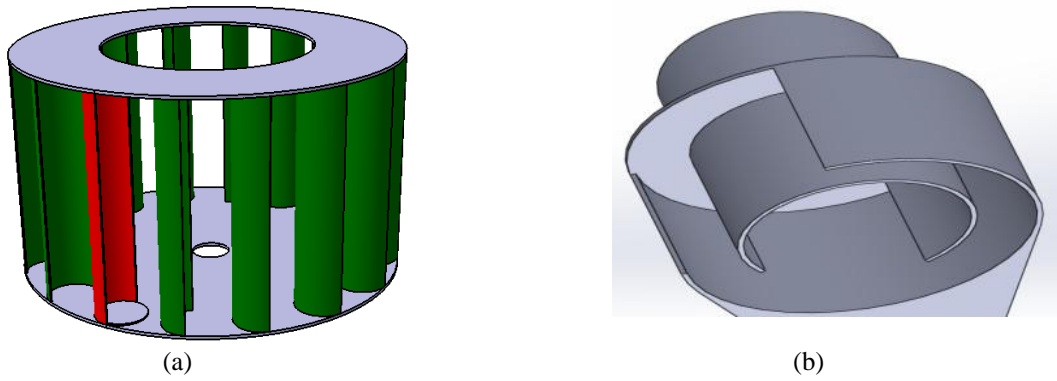

Fig. 4: (a) A 3D model of the 16-bladed turbine rotor and (b) the cowling device.

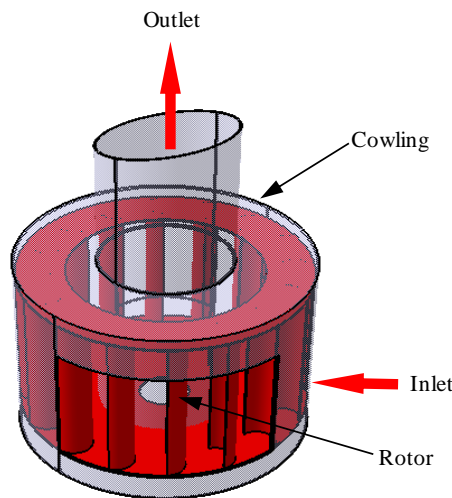

Fig. 5: Wind turbine rotor including the cowling assembled together.

The RMIT Industrial Wind Tunnel was used to measure the torque and rpm of the wind turbine. The tunnel is a closed return circuit wind tunnel. The maximum speed of the tunnel is approximately 145 km/h. The rectangular test section dimensions are 3 meters wide, 2 meters high and 9 meters long, and the tunnel's cross sectional area is 6 square meters. A plan view of the tunnel is shown in Fig. 6. The tunnel was calibrated

prior conducting the experiments and air speeds inside the wind tunnel were measured with a modified National Physical Laboratory (NPL) ellipsoidal head pitot-static tube (located at the entry of the test section) which was connected through flexible tubing with the Baratron® pressure sensor made by MKS Instruments, USA.

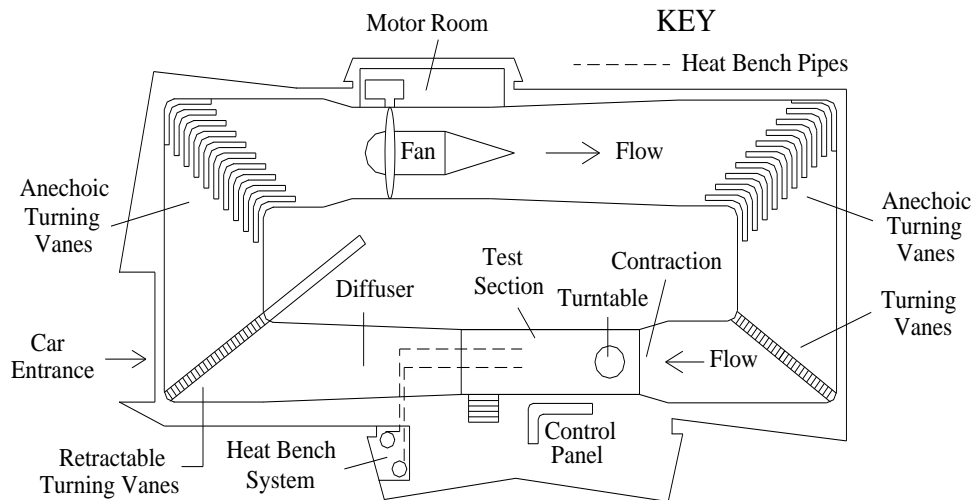

Fig. 6: A plan view of RMIT Industrial Wind Tunnel.

The experimental turbine model was connected through a mounting sting with the torque transducer (model: T20WN, manufactured by HBM GmbH, Germany) and a mechanical breaking system through a circular rod and bearing supports. Fig. 7 shows the schematic of the experimental setup.

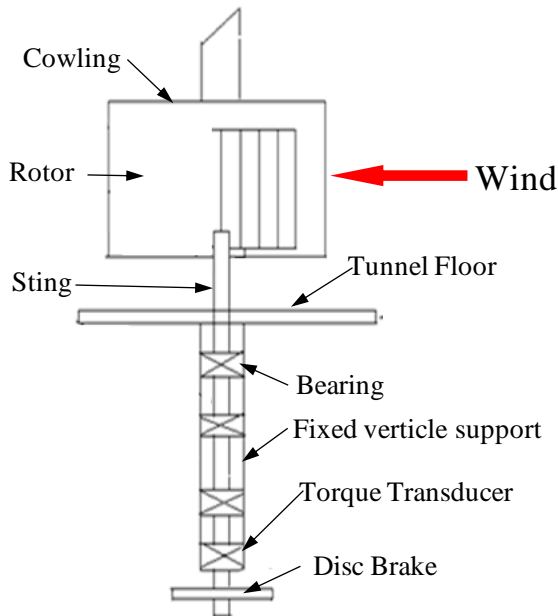

Fig. 7: Schematic of the experimental setup.

The setup was positioned at the middle of the wind tunnel test section and fixed properly on top of the wind tunnel floor to minimize vibration and measurement errors. The setup was positioned 150 mm above the tunnel floor to minimize boundary layer effect. Fig. 8 shows the experimental setup inside the RMIT Industrial Wind Tunnel.

Tests were conducted at a range of wind speeds (20 to 45 km/h with an increment of 5 km/h) under 0° yaw angles. The torque transducer has the maximum capacity of 5 kN with 0.01% accuracy. Data logging software supplied by the torque transducer manufacturer was used to log the data (i.e., speed and torque). Each measurement was taken three times for each configuration and wind speed tested and the average values were presented in this study. The minimum wind speed was constrained by the ability of the turbine to overcome bearing friction and inertia. The upper limit of wind speed was limited by safety consideration due to structural resonant vibrations. Maximum torque at each speed tested was analyzed to calculate the maximum power using the following formula:

$$P = T\omega \quad (1)$$

3. RESULTS AND DISCUSSION

Two wind turbine rotors (16 and 8 blades) with and without the cowling device were tested under wind tunnel environment. Fig. 9 shows the variation of torque with rotor speeds at 20, 30 and 40 km/h wind speeds for the 16-blade rotor. It can be observed that the torque value increases with the increase of

wind speed. Fig. 10 shows the variation of maximum rotor speeds with wind speeds for each configuration tested. Linear relationships can be found with the rotor speed and the wind speed for all 4 configurations. Fig. 11 represents the maximum power curves for 2 configurations of turbine tested. It is found that 16-blade rotor with the cowling devise is more efficient (generates more power) at wind speeds below 45 km/h.

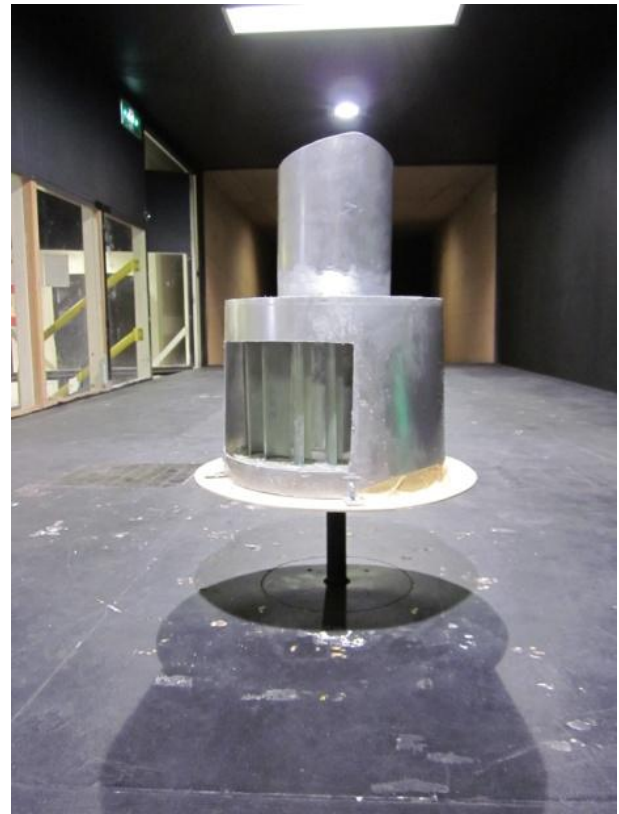

Fig. 8: Experimental setup inside the RMIT Industrial Wind Tunnel.

Results indicated an increase of rotor speed with the increase of wind speed for the baseline configuration: 16-blade rotor without a cowling device. The data from this study for this baseline configuration compares well with the investigation by Alam et al. [10]. The results also showed the similar trend for the other three configurations. However, the rate of change of rotor rpm over the wind speeds is different for each configuration. With the use of the cowling device, the average rotor speed increased by about 26% for the 16-bladed rotor compared to the baseline configuration. A significant increase (about 40%) of rotor speed was found for the 8-bladed rotor with the cowling device. However, a 12% decrease in speed was found while the number of blades was reduced to a half without the cowling device. Hence, it is clear from the experimental data that the cowling device has positive effect to increase the rotor speed to a significant amount.

The effectiveness of a domestic scale vertical axis wind turbine mainly depends on its power generation capability at low wind velocity. Therefore, it is important to analyze the power output over a range of wind speeds. The result showed that the baseline configuration indicated better power output capability than other three configurations up to 45 km/h wind speed.

However, the use of cowling with the 16-blade rotor showed an increase of power output of about 7% at 45 km/h. Similarly, the cowling device has increased the maximum power output significantly while used with 8-bladed rotor. The result showed about 159% increase of power with the 8-bladed rotor with the cowling device compared to the 8-bladed rotor with the cowling at 45 km/h wind speed. Therefore, it is clear that the cowling device can be used to increase the power output of this domestic scale vertical axis wind turbine especially with a reduce number of blades.

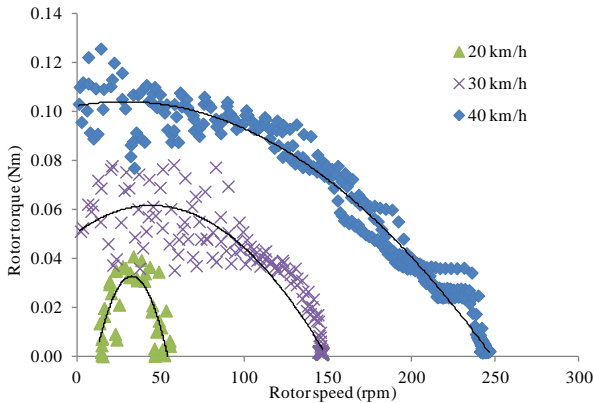

Fig. 9: Rotor speed as a function of torque for the 16-blade rotor without a cowling.

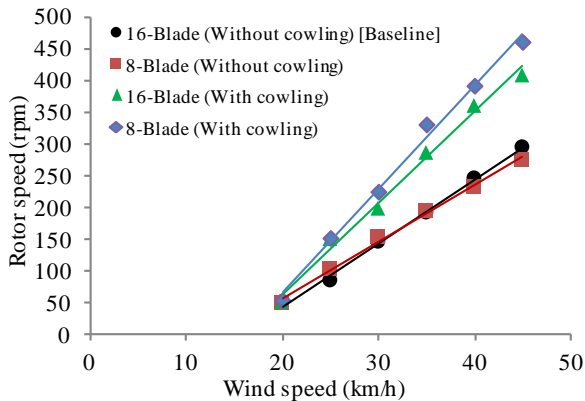

Fig. 10: Maximum rotor speed vs. wind speeds.

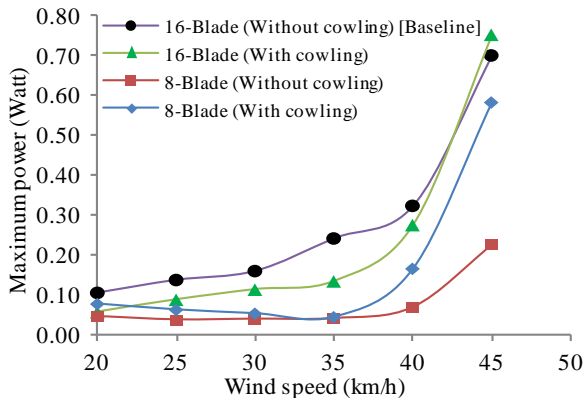

Fig. 11: Maximum power as a function of wind speeds.

4. CONCLUSIONS

The results showed that the cowling device has positive effect to increase the rotor speed to a significant amount. With the use of the cowling device, the average rotor speed increased by about 26% for the 16-bladed rotor compared to the baseline configuration. A significant increase (about 40%) of rotor speed was also found for the 8-bladed rotor with the cowling device. The results also indicated that the cowling device can be used to increase the power output of this cyclonic type vertical axis wind turbine especially with a reduce number of blades.

REFERENCES

- [1] A. C. Hansen and C. P. Butterfield, "Aerodynamics of Horizontal Axis Wind Turbines", Annual Review of Fluid Mechanics, Vol. 25, pp. 115–149, 1993.
- [2] H. Hirahara, M. Z. Hossain, M. Kawahashi and Y. Nonomura, "Testing basic performance of a very small wind turbine designed for multi-purposes", Renewable Energy, Vol. 30, pp. 1279–1297, 2005.
- [3] R. Howell, N. Qin, J. Edwards and N. Durrani, "Wind tunnel and numerical study of a small vertical axis wind turbine", Renewable Energy, Vol. 35, pp. 412–422, 2010.
- [4] K. Pope, I. Dincer and G. F. Naterer, "Energy and exergy efficiency comparison of horizontal and vertical axis wind turbines", Renewable energy, Vol. 35, no. 9, pp. 2102–2113, 2010.
- [5] A. D. Sahin, "Progress and recent trends in wind energy", Progress in Energy and Combustion Science, Vol. 30, pp. 501–543, 2004.
- [6] A. Ali, F. Alam, V. Djamovski and S. Watkins, "A review of power generation from wind in Australia", Proceedings of the 9th International Conference of Mechanical Engineering. (ICME2011), Dhaka, Bangladesh, pp. 1-6, December 18–20, 2011.
- [7] T. Ogawa, H. Yoshida and Y. Yokota, "Development of rotational speed control systems for a Savonius-type wind turbine", Journal of fluids engineering, Vol. 111, no. 1, pp. 53–58, 1989.
- [8] K. Irabu and J. N. Roy, "Characteristics of wind power on Savonius rotor using a guide-box tunnel", Experimental thermal and fluid science, Vol. 32, no. 2, pp. 580–586, 2007.
- [9] B. D. Altan, M. Atilgan and A. Özdamar, "An experimental study on improvement of a Savonius rotor performance with curtaining", Experimental and fluid science, Vol. 32, no. 8, pp. 1673–1678, 2008.
- [10] F. Alam and S. Golde, "An Aerodynamic Study of a Micro Scale Vertical Axis Wind Turbine", Procedia Engineering, Vol. 56, pp. 568–572, 2013.